



INSTALLATION INSTRUCTIONS FOR THE **ESCORT PASSPORT MAX** RADAR DETECTOR

Your rear view mirror has minimal clearance between the back side of the mirror and the mirror stem. It is very important that this mount is installed correctly to ensure mirror adjustability is retained.

PLEASE READ THESE INSTRUCTIONS THOROUGHLY BEFORE INSTALLING THIS MOUNT

NOTE: For illustration purposes, the mount and rear view mirror shown in these instructions may look slightly different than YOUR mount and rear view mirror.

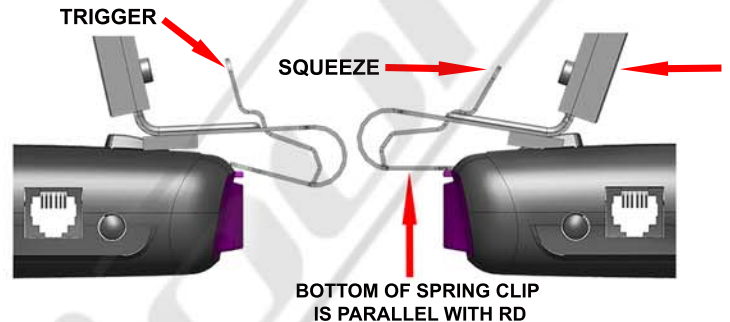

1 - The RELEASE Button on the radar detector (RD) is NOT used with this mount. To release the tension of the spring clip, simply squeeze the TRIGGER and the back side of the mount together. This will lower the bottom portion of the spring clip allowing you to slide the RD on and off. When used properly, the spring clip avoids putting excessive pressure on the mirror stem when installing and removing the RD. **The top portion of the mount should barely move when the two opposing forces are applied.**

2 - The bottom of the spring clip must be parallel with the top of the RD to slide in and out. SLIDE THE RD ONTO THE SPRING CLIP AS FAR AS IT WILL GO. Release the trigger to secure the RD onto the mount. Before installing the mount onto your rear view mirror, remove and install the RD a few times so you can observe how the spring clip functions.

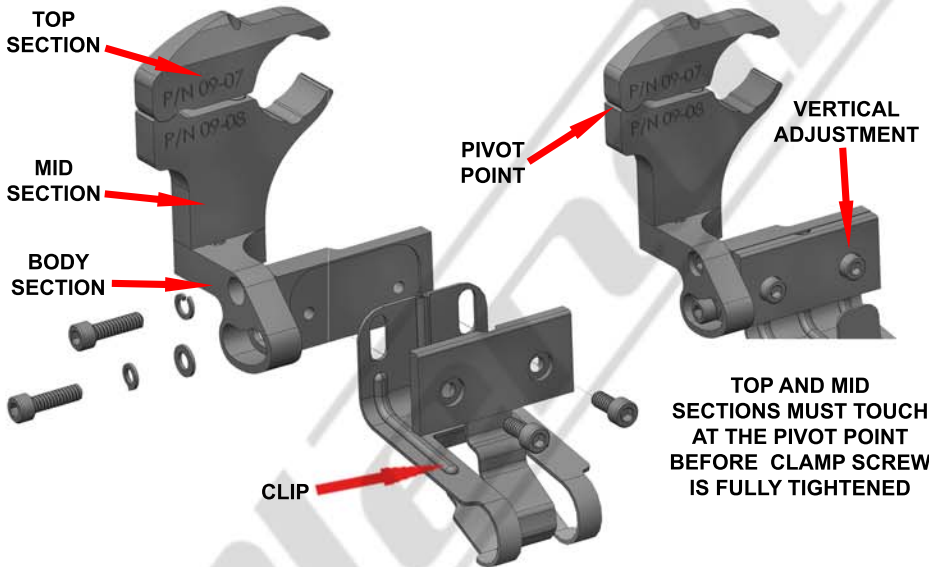

3 - Loosen the clamp screw so the top section separates from the mid section. This will provide the necessary clearance to slide the mount over the mirror stem as shown above. Adjust the mirror parallel to the windshield for ease of installation. As you are tightening the clamp screw, make sure the top and mid sections touch at the pivot point. **If they do not touch at the pivot point, this mount is incompatible with your mirror type.** Tighten the clamp screw until the mount is slightly snug around the mirror stem.

4 - Position the mount as far forward as you can. Before fully tightening the clamp screw, make sure the bottom of the mount is parallel with the bottom of the mirror.

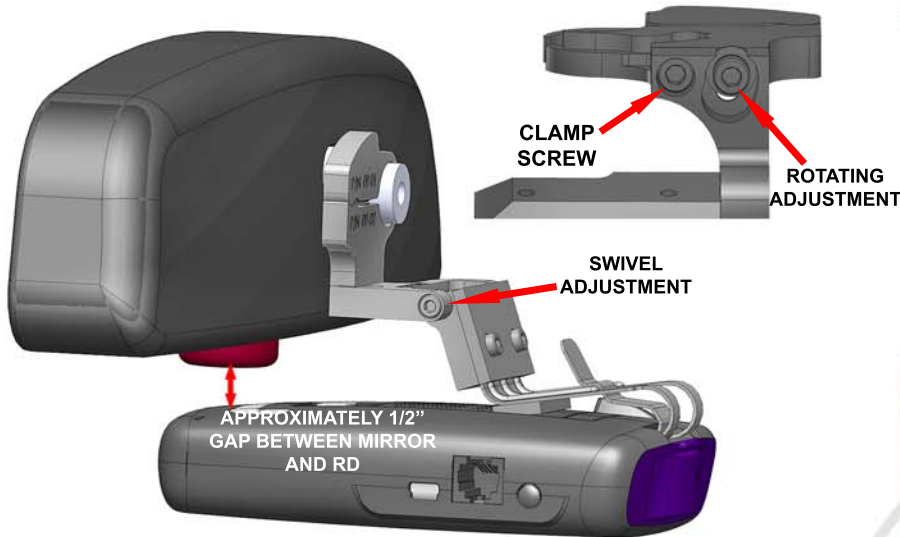

5 - Install the RD onto the mount. Make the necessary adjustments as shown above. Using the vertical adjustment, we recommend you adjust the RD so there is approximately 1/2" gap between the bottom of the mirror and the top of the RD. After all adjustments are made, be sure to check that all adjustment screws are tight. Grab the long arm of the allen wrench to assure that these screws are securely tightened. You will not strip out the tapped holes in the aircraft grade aluminum.

6 - To access the buttons of the RD you will need to gently push downward on the front of the RD with one finger and push the desired button with another finger. Then allow the RD to return to its original position by gently letting it spring upward. When accessing the buttons, be sure to push the RD downward just enough for your finger to fit between the RD and mirror. **Do not push down more than what is needed.**



7 - When removing or installing the RD, squeeze the trigger and the back side of the mount together with one hand, and lift the front of the RD upward with the other hand before sliding the RD off or onto the spring clip. **You must lift the front of the RD upward before sliding it off or onto the mount.**

NOTE : This mount can get extremely hot when sitting in direct sunlight. If you intend to remove your RD frequently, you may want to install the two gray "TOUCH STRIPS" included in the tool kit. Place them where your fingers make contact with the mount. They may be trimmed with a blade or knife.

FOR MORE INFO VISIT www.blendmount.com/videos

CAUTION

DO NOT use this mount if it interferes with the adjustability or the operation of your rear view mirror in any way.

DO NOT use this mount if the radar detector creates an unsafe viewing obstruction.

DO NOT ATTEMPT TO MODIFY THIS PRODUCT. Consult the manufacturer for assistance.

All BlendMount products are accompanied with detailed installation instructions and adjustment tips. You are encouraged to contact customerservice@blendmount.com or call J28 Design at 1-888-497-8388 for further assistance.

Check the BlendMount Forum for installation tips and some vehicle specific installs.
www.blendmount.com

Your feedback is very important to us. Please email any questions or comments you have to customerservice@blendmount.com